

**EM600 - MORTICE
W/O CONTACT
STAINLESS STEEL**

The EBELCO Stainless Steel series electromagnetic locks are renowned with its water-proof construction for all weathers used and the heavy duty with excellent holding force.

The series are compliance to CE and manufactured under the highest quality control to achieve the commitment to customer who always satisfied with maximum quality and reliability.

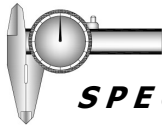

SPECIFICATIONS:

- ▶ **Voltage Input :** 12 VDC / 24 VDC
- ▶ **Current Draw :** 12V / 480mA ; 24V / 240mA (±5%)
- ▶ **Holding Force (Max) :** 600 lbs (272 kg)
- ▶ **Anti-Rust Surface Treatment :** Blue Zinc Plating
- ▶ **Operating Temperature :** 0~55° C (32~131° F)
- ▶ **Operating Humidity :** 0~95% (non condensing)
- ▶ **Weight (Magnet) :** 1.0 kg (±1%)
- ▶ **Dimensions :** Magnet - (L)195x(W)35.5x(T)27 mm
Armature - (L)180x(W)38x(T)11 mm



FEATURES:

- ▶ **Heavy Duty Stainless Steel Case For Vandal-Resistance and Anti-Corrosion Purposes**
- ▶ **Dual Voltage Selectable (12 VDC or 24 VDC)**
- ▶ **Low Current Consumption**
- ▶ **Reliable Holding Force**
- ▶ **Durable and Silence Operation**
- ▶ **Surge & Spike Protection PCB**
- ▶ **Anti Residual Magnetism Kick Off Button**

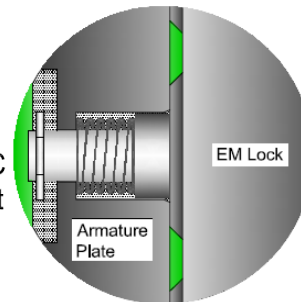
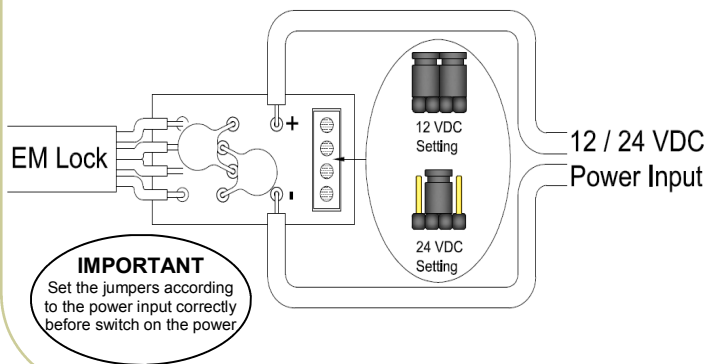

EM Lock Energized

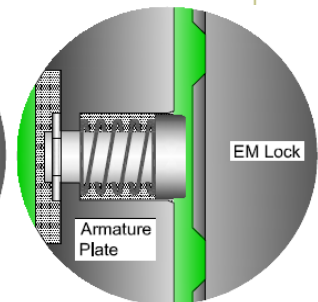

EM Lock De-energized

Disclaimer :

EBELCO reserve the right to go ahead with any modifications of models or features or price without forewarning. All the information and specifications stated in this document are current at the time of publication.

SECURITY . QUALITY . RELIABILITY