

The EBELCO 600 series electromagnetic locks are renowned with its excellent holding force and the remarkable features.

The series compliance to CE and PSB Test are manufactured under the highest quality control to achieve the commitment to customer who always satisfied with maximum quality and reliability.

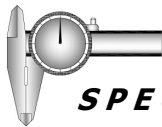

### SPECIFICATIONS:

- ▶ **Voltage Input** : 12 VDC / 24 VDC
- ▶ **Current Draw** : 12V / 480mA ; 24V / 240mA (±5%)
- ▶ **Holding Force** : Up to 600 lbs (272 kg)
- ▶ **Anti-Rust Surface Treatment** : Blue Zinc Plating
- ▶ **Operating Temperature** : 0~55° C ( 32~131° F)
- ▶ **Operating Humidity** : 0~95% ( non condensing)
- ▶ **Weight ( Magnet)** : 1 kg (±1%)
- ▶ **Dimensions** : Magnet - (L)220x(W)42x(T)25 mm  
Armature - (L)180x(W)38x(T)11 mm



### FEATURES:

- ▶ **Compact Size for Space Saving**
- ▶ **Dual Voltage Selectable (12 VDC or 24 VDC)**
- ▶ **Low Current Consumption**
- ▶ **Reliable Holding Force**
- ▶ **Durable and Silence Operation**
- ▶ **Cosmeticize Anodized Aluminum Casing**
- ▶ **Surge & Spike Protection PCB**
- ▶ **Anti-Tamper Jam Nuts**
- ▶ **Anti Residual Magnetism Kick Off Button**

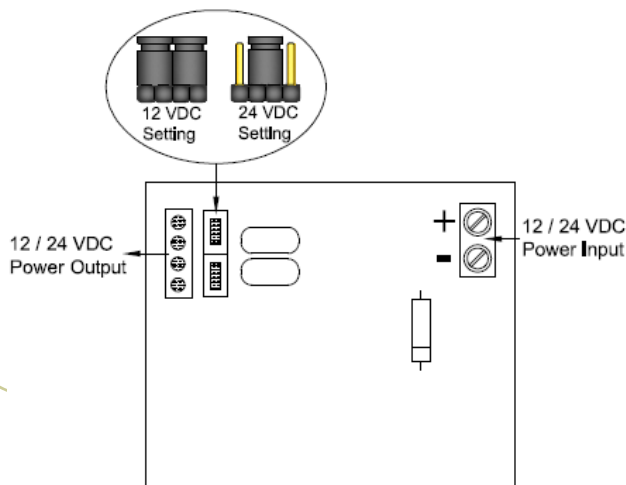

### IMPORTANT!

Set the jumper position according to the power input correctly before switch ON the power.

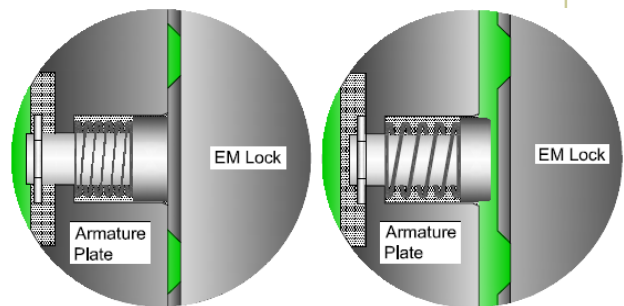

### Disclaimer :

EBELCO reserve the right to go ahead with any modifications of models or features or price without forewarning. All the information and specifications stated in this document are current at the time of publication.