

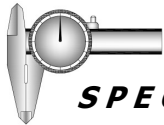

## EM 1200-MORTICE C/W CONTACT

The EBELCO 1200 series electromagnetic locks are renowned with its excellent holding force and the remarkable features.

The series compliance to CE and PSB Test are manufactured under the highest quality control to achieve the commitment to customer who always satisfied with maximum quality and reliability.



### SPECIFICATIONS:

- **Voltage Input :** 12 VDC / 24 VDC
- **Current Draw :** 12V / 420mA ; 24V / 210mA (±5%)
- **Holding Force (Max) :** 1200 lbs (545 kg)
- **Dry Reed Contact (Max) :** 100VDC, 0.25A, 3W
- **Anti-Rust Surface Treatment :** Blue Zinc Plating
- **Operating Temperature :** 0~55° C ( 32~131° F)
- **Operating Humidity :** 0~95% ( non condensing)
- **Weight ( Magnet ) :** 2.4 kg (±1%)
- **Dimensions :** Magnet - (L)190x(W)60x(T)38 mm  
Armature - (L)180x(W)38x(T)11 mm



### FEATURES:

- **Dual Voltage Selectable (12 VDC or 24 VDC)**
- **Low Current Consumption**
- **Reliable Holding Force**
- **Reed Contact Monitoring Output**
- **Durable and Silence Operation**
- **Surge & Spike Protection PCB**
- **Anti Residual Magnetism Kick Off Button**

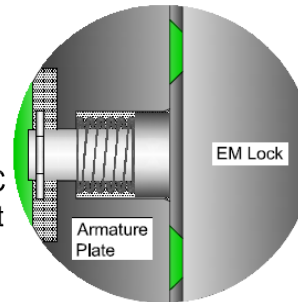
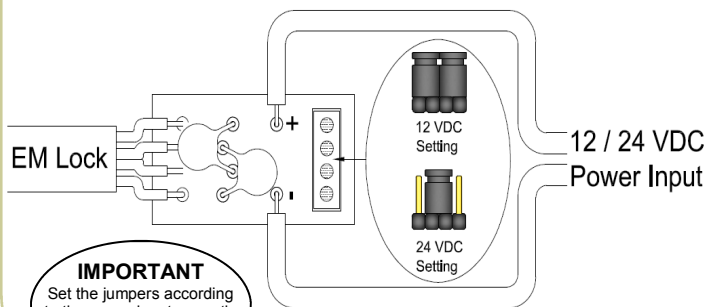

EM Lock Energized

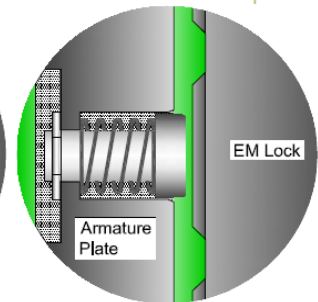

EM Lock De-energized

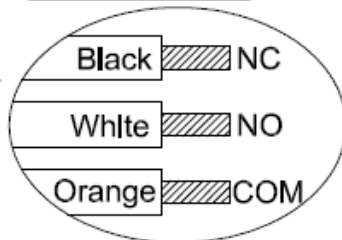

Dry Reed Instruction

### Disclaimer :

EBELCO reserve the right to go ahead with any modifications of models or features or price without forewarning. All the information and specifications stated in this document are current at the time of publication.

**SECURITY . QUALITY . RELIABILITY**