

Series Model

- SL-100D : Without door position detection output
- SL-100DA : With N.O. door position detection output
- BR-100D: Bracket (custom-made product)

Special features

- SL-100DA has door position output to support anti-pinch function.

- Special wearable design. Mechanic life of more than 1,000,000 times.
- Fail-safe type (power to lock), delay output point is available.
Open the lock before automatic door open to prevent both actions being stuck at the same time.
- Micro computer door position detection and current control to prevent error action and lower the lock's temperature.
- Stainless steel bolt is able to sustain more than 1200 kg of shear force.
- Built-in photo coupler door open push button input contact. Door will lock again automatically when door is not open within 5 seconds.

Specification Dimensions

	SL-100D	SL-100DA
Door Positions Sensor	×	N.O. Connector (0.25mA)
Power Supply	DC 12V±15%	
Operation current	900mA	
Holding current	360mA	
Application	For automatic door	
Delay Time	0,3,5,9 sec.(Available to set)	
Mechanic life	More than 1,000,000 times	
Output point	N.O. Connector	
Open door contact	Photo coupler contact	
MOV surge protection	Available	
Operation temperature	60°C ± 5°C (Room temperature 30°C)	
Output delay	0.5 sec.	
Legth of bolt	15mm	
Weight	860g(included wrapping)	

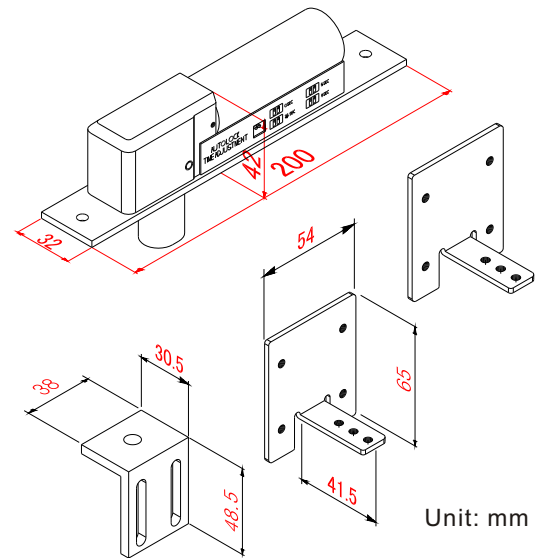

Structure diagram

