



Series Model

- SL-167A : With N.C. door position detection output
- SL-167B : With N.C. And N.O door position detection output

Special features

- 1 set of push button control contact is available.
- Lock indicator is available for lock status.
- Built-in microcontroller. Automatic current output control according to the door leaf position. The current is being lowered to 210mA after 6 seconds of door leaf positioning in order to cut down power consumption and lower the temperature of the lock body.

- Integrated surface-mounted designed for easy installation.
- Adjustable wiring hole according to the environment.
- Adjustable lock time(0 sec. & 3 sec.).
- Use for 9~12mm thickness frameless glass door.

Specification

	SL-167A	SL-167B
Door Positions Sensor	N.C.	N.C. & N.O.
Power Supply	DC 12V	
Operation current	570mA	
Holding current	210mA	
Application	90~180° glass door	
Delay Time	0,3 sec.(Adjustable)	
Mechanic life	more than 500,000 times	
Operation temperature	Maximum 45°C (Room temperature 30°C)	
Operation environment	Temperature 0-70°C, Humidity 85%Rh max	
Range of the door crack	Maximum of 6mm	
Bolt	14mm(Throw) x 12.7mm(Diameter)	
Weight	715g (included wrapping)	

Dimensions

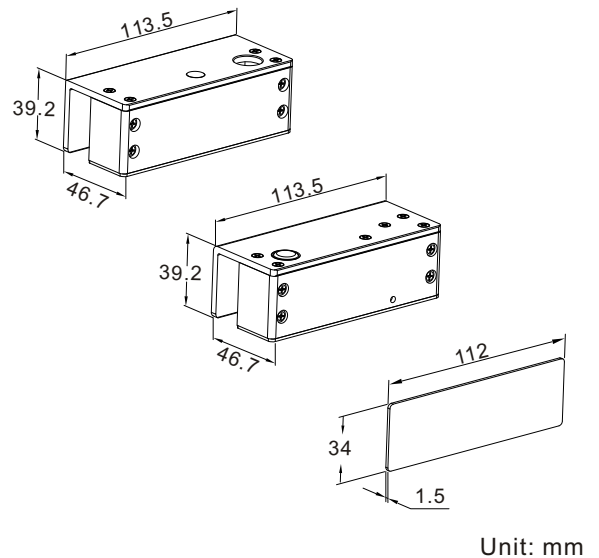

Installation

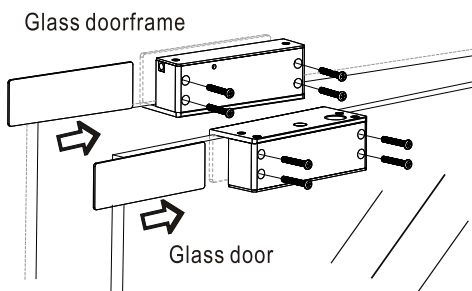

※Tighten the screw moderately in order to prevent mounting bracket to become deformed that stuck the bolt.

Attention

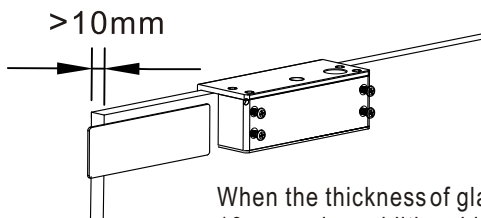

When the thickness of glass door is less than 10mm, using additive shims to increase thickness.

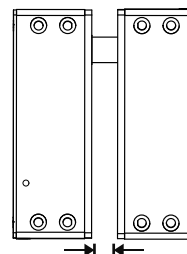

Maximum distance as 6mm.
It is unable to lock if the spacing is exceeding 6mm.

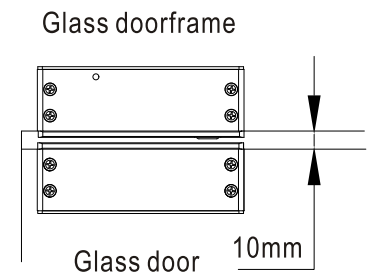

The spacing gap is suitable for 10~14mm