

CL400 - Code Change Instructions



Many Codes to Choose From

The CL400 code chamber (CL410 and CL420) consists of 13 buttons from which the code is selected, and a 'C' button which is used to re-set the chamber after an incorrect entry, and which must always be used as the first digit of a code. Buttons may only be used ONCE in a code. For example, 1212 is not possible.

A CL400 code, or combination, can be entered in any order or sequence; e.g. 1234 can be 4321 or 1342 or whatever sequence is most convenient to remember. With 13 buttons, a total of 8,191 different codes are available, any of which can be entered in any sequence.

The total is arrived at as follows:

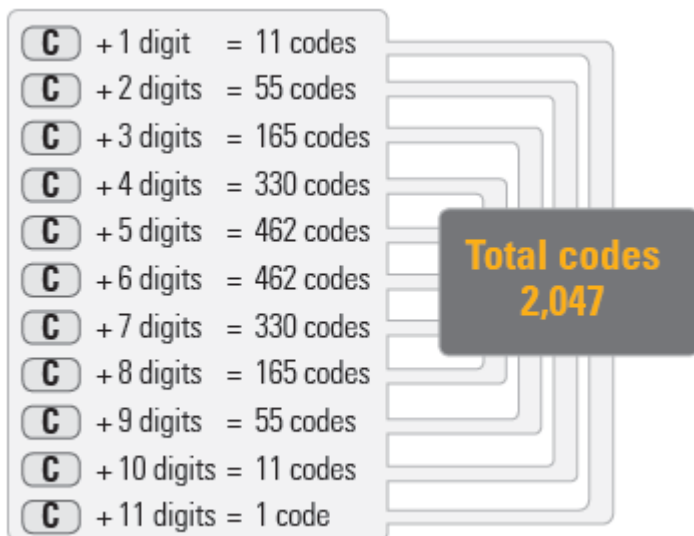

Most people will set a code in the range of 4 to 7 digits, and the total number of codes in this range is 5,434. The lock is factory set with a randomly selected 5 digit code starting with the 'C' button. The code is not recorded by the factory. The code can be changed as often as required to any other 5 digit code. Every new code must start with the 'C' button. Using the spare tumblers, the code length can be changed to 4 or 6 digits. Shorter codes are possible, but 1 or 2 digit codes are not recommended.

Note: CL415 and CL425 have 12 coded buttons giving 4,095 different codes.

Code Change Instructions

NOTE: On CL415 and CL425:

A) Press the 'Y' button and the 'C' button to ensure that the lock is not in Code Free Access mode.

B) When changing code do not reposition Y tumbler.

1. Take your CL400 lock off the door by unscrewing the 2 bolts in the back plate.
2. Press the C button to reset the chamber and place the lock case on a flat surface with the buttons down.
3. Remove the 2 red screws and carefully lift off the code chamber plate. Check that all 14 springs are held in place on the plate.
4. Note that the coloured code tumblers correspond in position to the existing code. The silver tipped non-code tumblers fill the other positions. The C tumbler is not coloured.

NB: Holding the C button depressed whilst repositioning the tumblers is ESSENTIAL to avoid damaging the internal mechanism. DO NOT attempt to reposition the C tumbler.

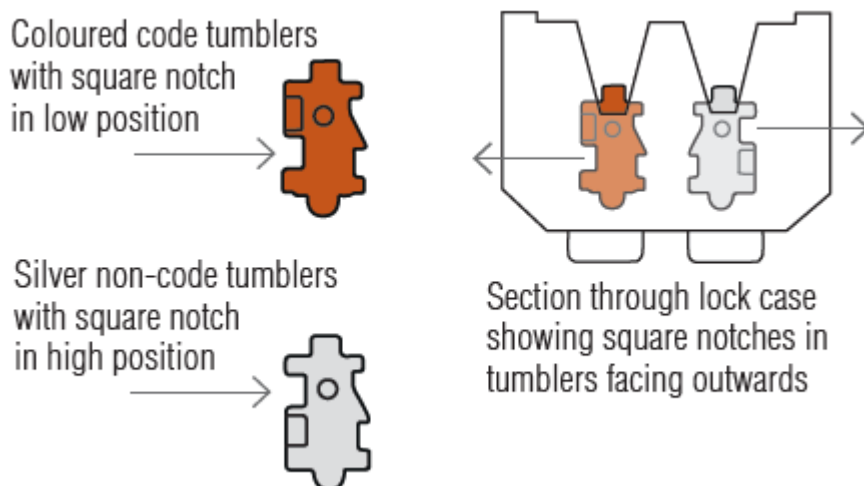

5. Hold the lock in your hand and depress the C button. Keeping the C button depressed use tweezers to reposition the tumblers to correspond with your new code. The square notches of ALL tumblers MUST face outwards, with the square tips ON TOP: See diagram below. DO NOT force the tumblers in.

6. Replace the code chamber plate carefully with the 2 red screws.

7. Check the operation of the new code, and make a written note of it before reinstalling the lock.



For door hung on RIGHT fit silver spindle on code side.



For door hung on LEFT fit coloured spindle on code side.



Fit the butterfly spindle to the inside, non-code side.

MAINTENANCE

No maintenance of the working parts is necessary. **DO NOT OIL.**

To maintain the finish the lock should be cleaned regularly with a soft cloth. A silicone spray or similar, should be used to provide a protective film against grit and grime.

GUARANTEE

If any Codelocks mechanical lock should develop a fault, at any time due to manufacturing, just call the Codelocks helpline and arrange for it to be repaired free of charge.

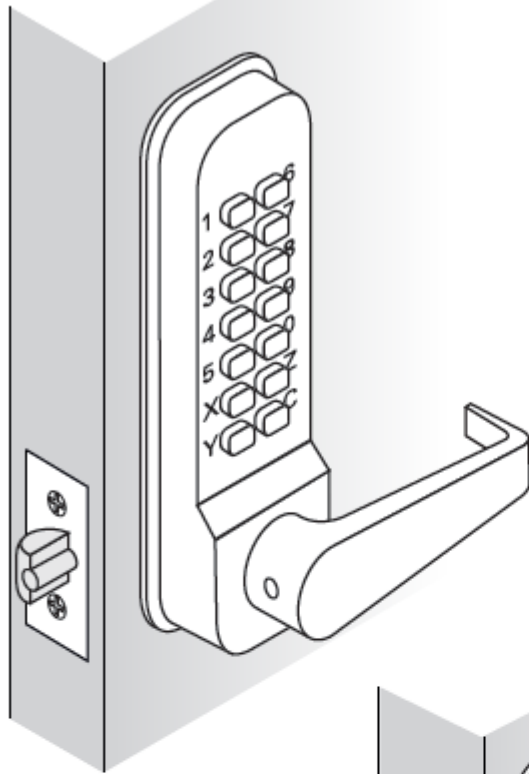

CL410/415
Tubular latchbolt

CL420/425
Mortice lock

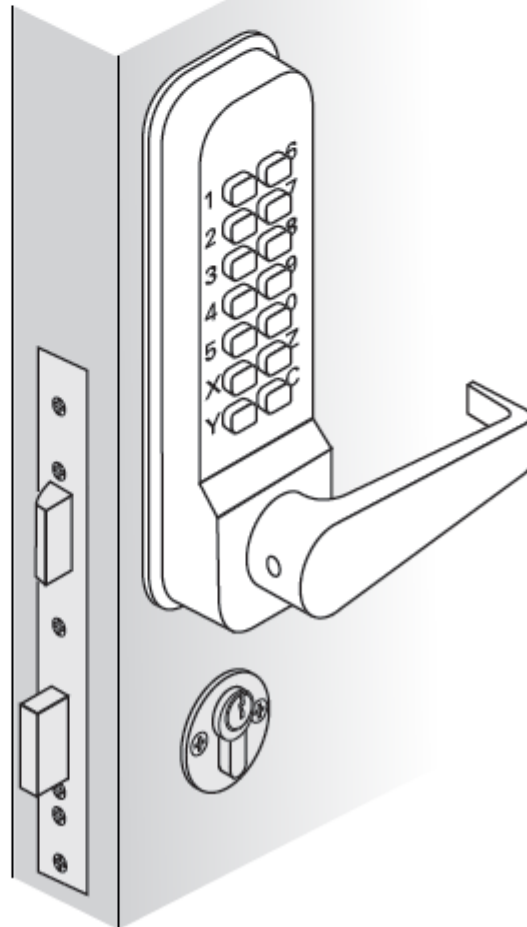

Features

- Medium-duty mechanical locks with full size lever handles.
- Code Free Access mode by pressing the 'Y' code free button after entering the code (CL415 and CL425 only). Reset by pressing the 'Y' button and then the 'C' button.
- Inside handle always retracts the latch for exit.
- Stainless steel and polished brass finishes available.
- Reversible handles.
- Easy code change as often as required.
- Fit doors between 35mm (1³/₈") - 60mm (2 3/8") thick

Features - Model 420/425 Only

- Split follower lock enables inside handle to retract latch and deadbolt simultaneously. Prevents accidental lock-ins
- Deadbolt thrown by key to lock out code users after work hours
- Key will retract the latchbolt giving access for admin functions
- Double Euro-profile cylinder with 3 keys. Any Euro-profile cylinder may be used excluding thumb turn version.
- On multiple door installations consideration should be given to having all cylinders keyed alike, with restricted key issue, for ease of management

Back to Back Version Only

- Two coded plates are provided to allow coded access in both directions.
- Butterfly spindle not required.
- For doors hung on the right, fit the silver spindle in the front keypad and the coloured spindle in the opposite side.
- For doors hung on the left, fit the coloured spindle in the front keypad and the silver spindle in the opposite side.

CL420 / CL425 Only

- Split follower lock enables inside handle to retract latch and deadbolt simultaneously. Prevents accidental lock-ins.
- Deadbolt thrown by key to lock out code users after work hours.
- Key will retract the latchbolt giving access for admin functions.
- Double euro profile cylinder with 3 keys. Any euro profile cylinder may be used excluding thumb turn versions.

- On multiple door installations consideration should be given to having all cylinders keyed alike, with restricted key issue, for ease of management.

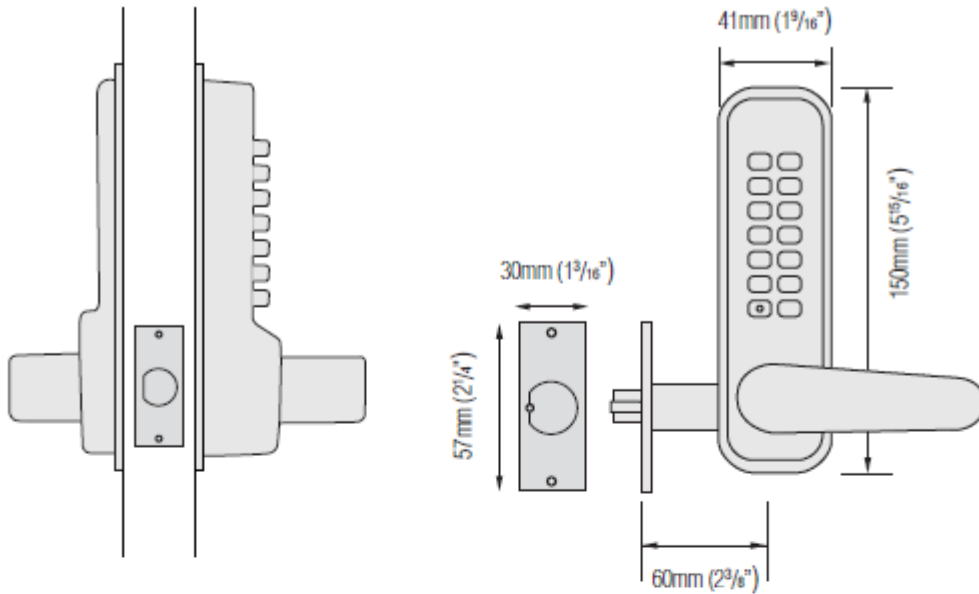

CL410/415 with tubular latchbolt

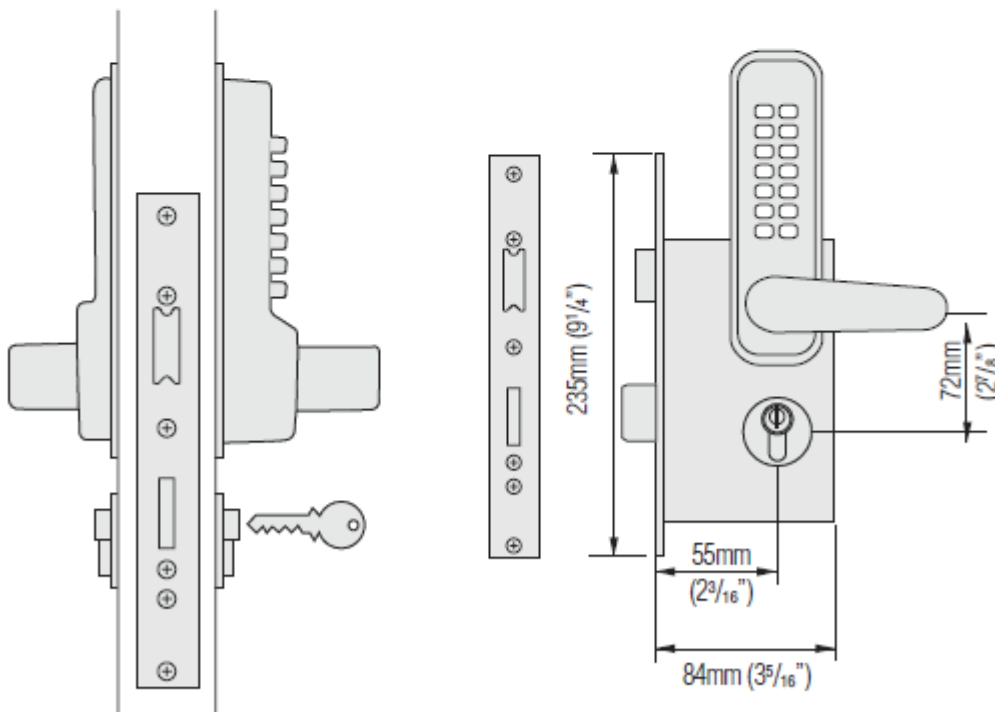

CL420/425 with full 'Panic Function' mortice lock and cylinder

